

产品规格书

Product Datasheet

FC5M-40MN-AC



HSC、PTO、晶体管、以太网 NPN、EtherNet

主要信息 Main

产品系列 Range Of Product	FC5
产品类型 Product Or Component Type	可编程控制器 Logic controller
额定电源电压[Us] Rated Supply Voltage	AC 100V~240V
离散量输入数量 Discrete Input Number	24 (7 Fast)
离散量输出类型 Discrete Output Type	晶体管 NPN Transistor
离散量输出数量 Discrete Output Number	16 (6 Fast)
离散量输出电压 Discrete Output Voltage	DC 5V~30V;
离散量输出电流 / 点 Discrete Output Current/Point	最大 2A, Max 2A
离散量输出电流 /Group Discrete Output Current/Group	最大 4A, Max 4A

补充信息 Complementary

晶体管输入 Transistor Input

特性 Characteristics		参数 Parameter
额定电压 Rated Voltage		DC 24V
输入范围 Input Range		DC 0V~28.8V
额定电流 Rated Current		7mA
峰值 Peak	电压 Voltage	30V
	电流 Current	9mA
状态 State	电压 (状态 1) Voltage in state 1	>15V
	电压 (状态 0) Voltage in state 0	<5V
	电流 (状态 1) Current in state 1	>2.5mA
	电流 (状态 0) Current in state 0	<1.0mA
隔离 Isolation	-	光耦 Optocoupler
输入阻抗 Input impedance		3.3k Ω
滤波时间 Filter time		默认 1ms, 无滤波到 100ms 平分 16 等级可选 Default 1ms, 16 equally divided levels selectable from unfiltered to 100ms
兼容性 Compatibility		兼容 2 线制/3 线制传感器 Compatible with 2/3 wire sensors
输入类型 Input type		源型/漏型 Source/Sink
线缆长度与类型 Cable length and type		最长 100m 屏蔽电缆或 50m 非屏蔽电缆 Max 100m shielded cable, 50m unshielded cable
保护 (过电压) Protection (overvoltage)		最大 30V, 限制每天 1 小时发生频率 Maximum 30V, limited to 1 hour per day frequency
接线端子 Wiring terminal		可拆卸端子台 Removable terminal block

晶体管输出特性 Transistor Output

特性 Characteristic	参数 Parameter
输出类型 Output type	NPN
额定电压 Rated voltage	DC 24V
电压范围 Voltage range	DC 19.2V~28.8V
额定电流 Rated current	2A
电流/组 Current/group	4A*每组的输出点数 4A* Output point of each group
压降 Voltage drop	最大 DC 1V Maximum 1V DC
关闭时漏电流 Leakage current when turned off	<5 μ A
纯电阻负载最大功率 Maximum power of incandescent lamp	2.4W
降容 Derating	无 None
开启时间 Start time	最大 34 μ s Maximum 34 μ s
关闭时间 Turn-off time	最大 250 μ s Maximum 250 μ s
最高输出频率 Maximum output frequency	1kHz
短路保护 Short circuit protection	有 Yes
短路输出峰值电流 Peak short-circuit output current	1.3A
短路或过载后自恢复 Self-recovery after short circuit or overload	每 10ms Per 10ms
钳制电压 Clamping voltage	最大 DC 39V \pm 1V Maximum 39V \pm 1V DC
隔离 Isolation	输出与内部逻辑间 AC 500V 500V AC between output and internal logic
电缆类型 Type of Cable	非屏蔽 Unshielded
电缆长度 Cable length	50m 非屏蔽线缆 Unshielded 50m
接线端子 Wiring terminal	可拆卸端子台 Removable terminal block

快速晶体管输出特性 Fast Transistor Out

特性 Characteristics	参数 Parameter
额定电压 Rated voltage	24 V DC
电压范围 PTO Power input range	19.2V~28.8V DC

电源反接保护 PTO Power reverse protection	Available
输出类型 Output type	NPN or PNP (based on controller model)
输出电流 PTO/PWM output current	0.5A (when used as normal output)
	0.1A (when used as a fast output)
绝缘电阻 Insulation resistance	> 10 MΩ
泄露电压 Leakage voltage	< 1.5V (Current is 0.1A)
最小负载阻抗 Minimum load impedance	80Ω
最大 PTO 输出频率 Maximum PTO output frequency	◆ NPN: 200kHz ◆ PNP: 100kHz
最大 PWM 输出频率 Maximum PWM output frequency	50kHz
占空比分辨率 Duty cycle resolution	Not greater than 0.5%
占空比范围 Duty cycle range	0%~100%
运行模式 Operating mode	Pulse/direction output
电缆长度 Cable length	Maximum 5m
电缆类型 Cable type	Shielded cable, including 24V DC power supply
接线端子 Wiring terminal	Removable screw terminals

环境特性 Environmental Characteristics

类别 Category	特性 Characteristic
运行环境温度 Operating ambient temperature	-10°C~60°C
存储温度 Storage temperature	-20°C~70°C
相对湿度 Relative humidity	55%~95%, 无凝露 without condensation
污染等级 Class of pollution	2 (IEC60664)
防护等级 Class of protection	IP20
涂层 Coating	涂层防护, 干膜厚度≥20μm; 加强版干膜厚度≥40μm Coated protection, dry film thickness ≥ 20μm; reinforced dry film thickness ≥ 40μm

海拔高度 Altitude	运行: 0m~3,000m Operation: 0m~3,000m 运输: ≤6,000m Transportation: ≤6,000m
抗震性能 Seismic performance	5Hz~13.2Hz, 振幅 7mm; 13Hz~100Hz, 加速度 2G, X、Y、Z 三轴方向各 20 次 5~13.2Hz Amplitude 7mm, 13Hz~100Hz Acceleration 2G, 20 times each in X, Y and Z axes
抗冲击性能 Impact performance	半正弦波, 加速度 15G, 持续 11ms, X、Y、Z 三轴方向各 6 次 Semi-positive sine wave, acceleration 15G, duration 11ms, 6 times in each of the X, Y and Z directions

电磁敏感性 Electromagnetic Susceptibility

Standard	Method	Item
EN IEC 61000-6-4:2019	CISPR 16-2-1	Conducted Emissions at AC Mains Power Port (150kHz-30MHz)
	CISPR 32	Conducted Emissions at Wired Network Port(150kHz-30MHz)
	CISPR 16-2-3	Radiated Emissions(30MHz-1GHz)
	CISPR 16-2-3	Radiated Emissions(Above 1GHz)
EN IEC 61000-6-2:2019	EN 61000-4-6:2014	Conducted Immunity at AC Mains Power Port(150kHz-80MHz)
	EN 61000-4-6:2014	Conducted Immunity at Signal Port150kHz-80MHz
	EN 61000-4-4:2012	Electrical Fast Transients Burst at AC Mains Power Port
	EN 61000-4-4:2012	Electrical Fast Transients Burst at Signal Port
	EN 61000-4-2:2009	Electro static Discharge
	EN 61000-4-8:2010	Power Frequency Magnetic Field
	EN IEC 61000-4-3:2020	Radiated Immunity(80MHz-6GHz)
	EN 61000-4-5:2014+A1:2017	Surge at AC Mains Power Port
	EN 61000-4-5:2014+A1:2017	Surge at Signal Port
	EN IEC 61000-4-11:2020	Voltage Dips and Interruptions

F5 系列交流电源型 PLC 系统符合下述的安全标准:

The F5 Series AC power supply type PLCs system meets the following safety standards:

- IEC 61010-1:2010 + A1:2019
- AMD1: 2016

安全注意事项 Safety notes

- ◆ 如果不能保持在指定的电压范围内，则可能无法按预期切换输出。请使用合适的安全联锁和电压监控电路。If the specified voltage range cannot be maintained, the output may not switch as expected. Please use a proper safety interlock and voltage monitoring circuit.
- ◆ 对于继电器输出（大于等于 2A）接线，请使用横截面积至少为 0.5 平方毫米且额定温度至少为 80°C 的导体。For relay output ($\geq 2A$) wiring, use a conductor with a cross-sectional area of at least 0.5 mm² and a rated temperature of at least 80°C.

请确保外部提供的交流电源满足以下特性要求。Make sure the external AC power supply meets the following characteristic requirement.

特性 Characteristic		值 Value
电压 Voltage	额定值 Rated	AC 100V~240V
	限制 Limited	AC 85V~264V
频率 Frequency	额定值 Rated	50/60Hz
	限制 Limited	45/66Hz
电源中断时间 Power interruption time		AC 100V 时为 10 毫秒 10 ms at 100V AC
最大峰值电流 Maximum peak current	AC 240V	40A
最大功耗 Maximum power consumption	F*5-20MR-AC	<30W
	F*5-30MR-AC	<30W
	F*5-40MR-AC	<30W
隔离 Isolation	AC 电源与内部逻辑之间 Between AC power and internal logic	AC 2300V
	AC 电源与保护性接地之间 Between AC supply and protective earthing	AC 1500V

连接交流电源线的操作方法如下：The method of connecting DC power cords is as follows：

- 步骤1. 将交流电源的火线连接至设备电源输入的“L”端子。Connect the AC power fire wire to the "L" terminal of the PLC power input.

步骤2. 将交流电源的零线连接至设备电源输入的“N”端子。Connect the zero cord of the AC power supply to the "N" terminal of the PLC power input.

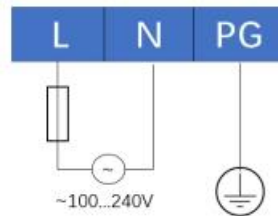

连接数字输入端子 Digital Input Wiring Diagram

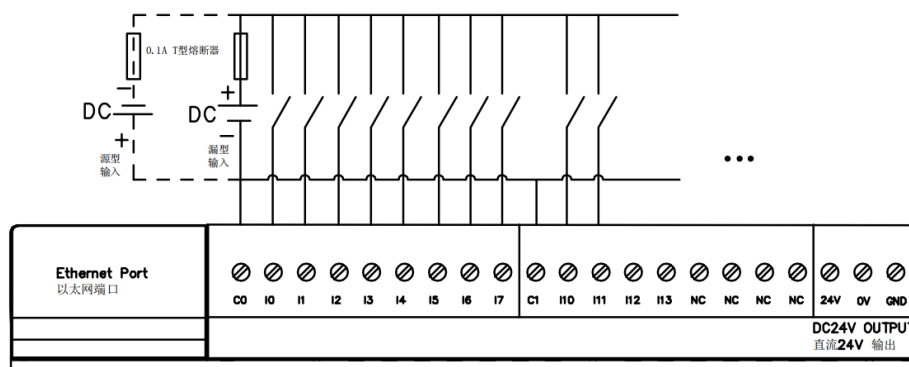

◆ 因为公共端 C0/C1/C2 彼此独立，使用相同输入类型时，请使用短接线将公共端连接。As the common terminals C0/C1/C2 are independent of each other, when using the same type of input, please connect the common terminals using short wires.



使用高速脉冲输入时，请使用屏蔽线缆并保证良好接地。When using the high speed pulse input, use a shielded cable and keep it well earthed.

连接继电器输出端子 Relay Output Wiring Diagram

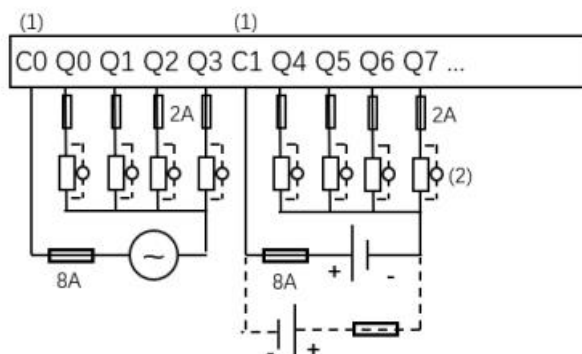

C0 和 C1 端子未在内部连接。C0 and C1 terminals are not connected internally.

为了延长触点的使用寿命，以及防止潜在的电感性负载损坏，您必须将续流二极管并行连接到每个电感性直流负载或将 RC 缓冲器并行连接到每个电感性交流负载。To extend the life of the contacts and to prevent potential damage to inductive load, you must connect a freewheel diode in parallel to each inductive DC load or an RC buffer in parallel to each inductive

AC load.

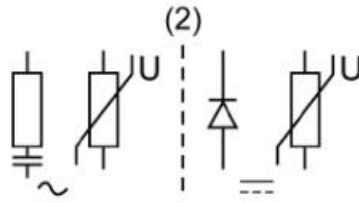

请在使用交流电源情况下确认负载耐压等级是否满足要求。Please check that the load withstand voltage level meets the requirements when using AC power.

连接 USB 接口 Connect to USB Port

用户可通过 USB 接口对 PLC 进行编程调试。连接 USB 端口的操作方法如下：You can program for the PLC via USB interface. The method of connecting USB ports is as follows:

步骤3. 将 USB 连接线缆的 Type-C 端连接至 PLC 的 USB 接口。Connect the Type-C end of the USB connection cable to the USB interface of the PLC.

步骤4. 将 USB 连接线缆的 Type-A 端连接至 PC 的 USB 接口。Connect the Type-A end of the USB cable to the USB interface of the PC.



连接以太网接口 Connect to Ethernet Port

PLC 的以太网接口为 RJ45 接口，速率为 10M/100Mbit/s，自适应半双工/全双工。Ethernet interface is RJ45 type, 10Mbps/100Mbps, adaptive/half full duplex.

下图展示了以太网连接器引脚定义。The following diagram shows the Ethernet connector pin definitions:

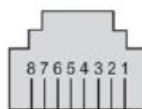

引脚号	信号
1	TD+
2	TD-
3	RD+

4	-
5	-
6	RD-
7	-
8	-

使用 RJ45 标准以太网线缆连接 PLC 的以太网端口及对端设备（如 PC）的以太网端口。Using RJ45 standard Ethernet cable to connect Ethernet ports of PLC to Ethernet port of device such as PC.

连接串行通讯接口 1 Connect to Serial Communication Port 1

PLC 的串行通讯接口 1 如下图红色方框标记处所示。使用 DB9 插头连接至该接口。The position of serial port 1 of the controller is shown below, connect to the port using the DB9 plug.



串行通讯接口 1 为 DB9 型式，支持 RS485 或者 RS232 通讯，引脚定义如下。Serial communication port 1 is DB9 type and supports RS485 or RS232 communication with the pin definitions as follows.

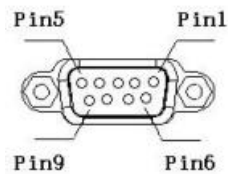

引脚号 Pin	串口 1 (RS485) Port1	串口 1 (RS232) Port1
1	RS485- (B)	-
2	-	RXD
3	-	TXD
4	-	-

5	GND	GND
6	RS485+ (A)	-
7	-	-
8	-	-
9	-	-

连接串行通讯接口 2 Connect to Serial Port2

PLC 的串行通讯接口 2 如下图红色方框标记处所示。The position of serial port 2 (with photoelectric isolator) of the controller is shown below.



引脚定义如下: The pin definition of serial port 2 is as follows

- ◆ A: RS485 +
- ◆ B: RS485 -
- ◆ GND: 屏蔽接地 Shield grounding

使用双绞线连接至 A 端子和 B 端子, 双绞线的另一端分别连接到对端设备串口的 RS485+和 RS485- 端子即可。Use twisted pair wire to connect to A and B terminals, and the other end of twisted pair to RS485 + and RS485- terminals to the serial port of the peer device, respectively.

CPU 尺寸 Dimension

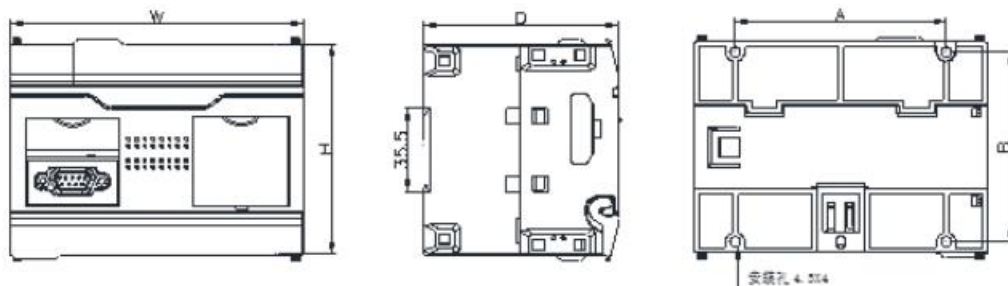

单位 Unit mm

型号 Model	点数 IO	导轨尺寸 Guide rail dimension	螺丝孔安装尺寸 Mounting dimensions for screw holes		外形尺寸 Dimension W×H×D
			A	B	

F*5-20M△-◎	20	35	90	81	125×90×83
F*5-30M△-◎	30				
F*5-40M△-◎	40		137	81	

产品型号△标识，当△为 R：主机输出为继电器机型；当△为 N 或 P：主机输出为晶体管机型。

产品型号◎标识，当◎为 AC：主机供电电源为 AC 220V；当◎为 DC：主机供电电源为 DC 24V。

Product model △ mark, when △ is R—the host outputs are relay models, when △ is N or P—the host outputs are transistor models;

Product mode ◎ mark, when ◎ is AC—power supply for the host is 220V AC, when ◎ is DC—power supply for the host 24V DC;

通风要求 Ventilation requirements

设备需要安装在通风条件良好的机柜中，并确保设备周围留有足够的空间便于设备散热。The equipment needs to be installed in a cabinet with good ventilation conditions and to ensure that there is enough space around the equipment to allow it to dissipate heat.



- 将散热量最多的设备安装在机柜顶部，以确保适当通风。Install the equipment that dissipates the most heat on top of the cabinet to ensure proper ventilation.
- 请勿将该设备安装在可能引起过热的设备旁边或上方。Do not install the equipment next to or above equipment that may cause overheating.
- 为保证设备良好运行，请确保设备的工作环境温度在 0°C~50°C。 To ensure that the equipment works well, please keep the ambient temperature between 0 °C and 50 °C.

最小间隙 Minimum Spacing

确保设备能够正常散热，请保留足够的间隙距离。有以下 3 种类型的间隙：The F5 Series PLCs have an IP20 protection grade and must be installed in a chassis. The installation spacing must be taken into account when installing this product. There are 3 types of spacing as follows:

- ◆ 设备与机柜的所有侧面（包括面板门）之间的间隙。Spacing to all sides of the cabinet (including panel doors).
- ◆ 端子块与接线管道之间的间隙。此距离可减小控制器和接线管道之间的电磁干扰。Spacing between the terminal block and the wiring duct. This distance reduces electromagnetic interference between the controller and the wiring ducts.
- ◆ 与安装在同一机柜中的其他发热设备之间的间隙。Spacing to other heat generating equipment installed in the same cabinet.

下图为 PLC 安装的最小间隙要求（PLC 上面板、下面板、左面板、右面板距离机柜侧面的间距至少为 30mm，PLC 前面板距离面板门间距至少为 80mm）。The following diagram shows the minimum spacing for the F5 Series PLCs installation (the spacing between PLC upper panel (lower panel, left panel, or right panel) and cabinet sides is at least 30mm; the spacing between PLC front panel and cabinet door is at least 80mm).

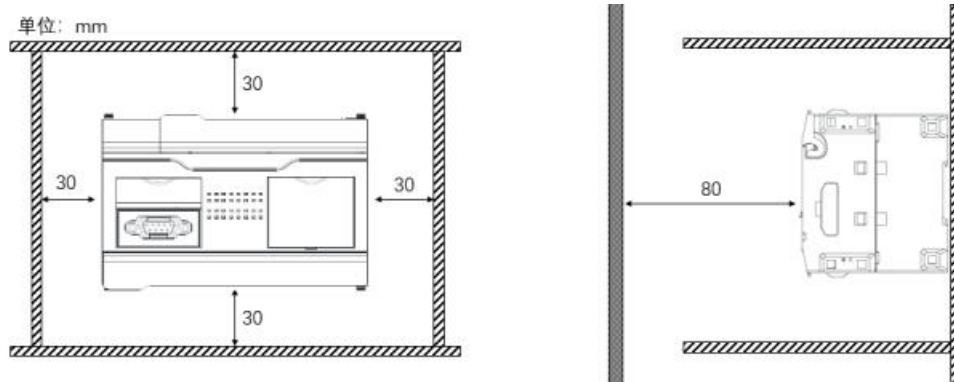

防异物贴纸 Anti-foreign object sticker

安装时请勿移除防异物保护贴纸，避免安装过程有异物掉入机器内，引起短路等故障；安装完成后通电前必需移除防异物保护贴纸，避免散热不良导致 PLC 过热引发异常。Do not remove the anti-foreign object protection sticker during installation to prevent foreign objects from falling into the machine and causing short circuits and other faults. After installation and before powering up the unit, the anti-foreign object protection sticker must be removed to avoid overheating of the PLC caused by poor heat dissipation.

安装扩展模块（可选） Installation of the Left and Right Extension Module (Optional)

PLC 可在 CPU 本体左右两侧安装扩展模块以扩展 PLC 的功能。安装扩展模块的操作方法如下：

步骤1. 将主机左（右）侧边锁扣朝解锁方向推进解锁。Unlock the mainframe by pushing the left (right) side latch towards the unlocking direction.

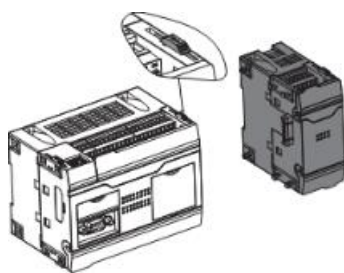

步骤2. 将扩展模块对准主机接口推入到位后，反向推回锁扣进行扩展模块锁定。Then push the extension module into place against the mainframe interface and reverse the latch to lock the extension module.



步骤3. 后续如需添加其他扩展模块，重复上述步骤即可。Add subsequent extension modules and repeat Step1 and Step2.

安装扩展板（可选） Installation and Removal of Extension Boards (Optional)

步骤1. 在 CPU 本体打开扩展板盖板。Open the cover as shown 。

步骤2. 将扩展板对准安装位置，将扩展板插入扩展槽位并扣紧。After aligning the extension plate with the installation position, press down to secure it.

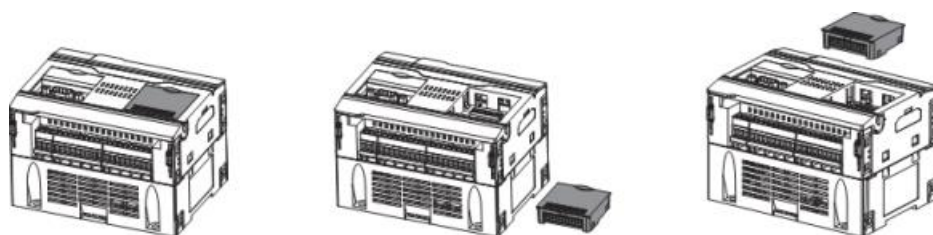

在面板上安装设备 Installation of Direct Panel Surface

步骤1. 根据设备实际安装孔的间距在面板上确定四个安装孔的位置，用记号笔打上标记。Determine the position of the four mounting holes on the panel based on the spacing of the actual installation holes of the device, and mark them with markers.

- 下图为具有 20/30 点 I/O 的 CPU 本体的安装孔间距 The following diagram shows the mounting holes for the 20/30 points I/O CPU.

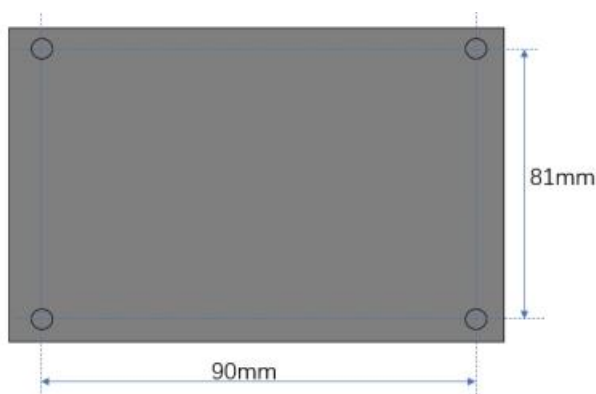

- 下图为具有 40 点 I/O 的 CPU 本体的安装孔间距 The following diagram shows the mounting holes for the 40 points I/O CPU.

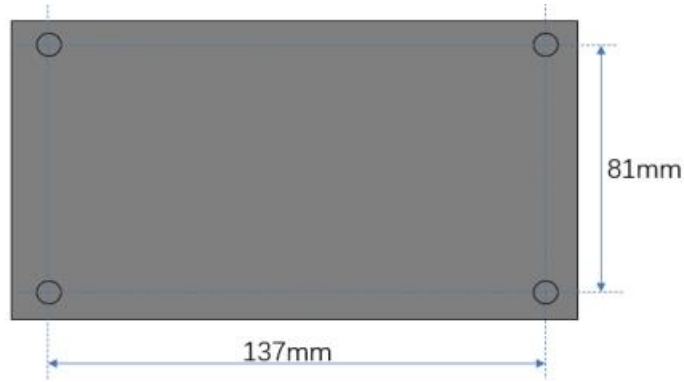

步骤2. 使用钻孔设备在面板上已标记的安装孔位置钻孔。Use drilling equipment to drill holes in marked mounting positions on the panel.

步骤3. 根据安装面板材料选择合适的螺钉，将螺钉对准备安装孔，并调整设备的位置，拧紧螺钉，将设备固定在面板上。Select the appropriate screw according to the mounting panel material, point the screw at the device mounting hole, and adjust the position of the device, tighten the screw, and secure the device to the panel.

在 DIN 导轨上安装设备 Installation of DIN Rail

可通过 DIN 导轨将设备安装至机柜。操作方法如下：The controller and its extension modules can be installed on DIN rails which can be fitted to a flat installation surface.

步骤1. 准备以下规格的 DIN 导轨，并将 DIN 导轨安装至机柜。Prepare DIN rails of the following specifications and install DIN rails into the cabinet.

推荐用于 PLC 安装的 DIN 导轨高 35 毫米，深 7.5 毫米。The recommended DIN rail for PLC installation is 35 mm high and 7.5 mm deep, as shown below.

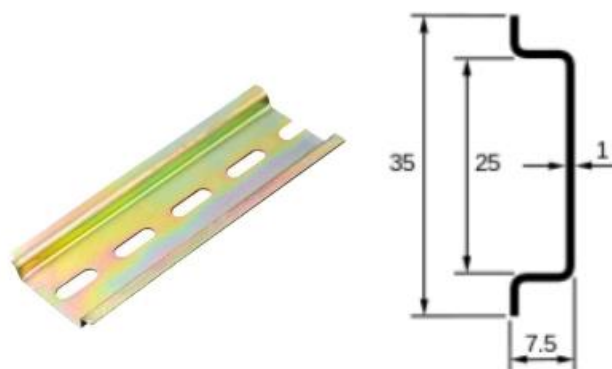

步骤2. 将设备 DIN 安装槽的上端卡入 DIN 导轨的上端，用力按压设备，将设备 DIN 安装槽的下端卡入 DIN 导轨的下端。Insert the upper end of the DIN slot into the upper end of the DIN rail, press the equipment hardly, and insert the lower end of the DIN slot into the lower end of the DIN rail.

